

CANDIDATE  
NAME

CENTRE  
NUMBER

--	--	--	--	--

CANDIDATE  
NUMBER

--	--	--	--



**PHYSICS**

**5054/21**

Paper 2 Theory

**October/November 2016**

**1 hour 45 minutes**

Candidates answer on the Question Paper.

No Additional Materials are required.

**READ THESE INSTRUCTIONS FIRST**

Write your Centre number, candidate number and name on all the work you hand in.

Write in dark blue or black pen.

You may use an HB pencil for any diagrams or graphs.

Do not use staples, paper clips, glue or correction fluid.

DO **NOT** WRITE IN ANY BARCODES.

**Section A**

Answer **all** questions.

Write your answers in the spaces provided on the Question Paper.

**Section B**

Answer any **two** questions.

Write your answers in the spaces provided on the Question Paper.

Electronic calculators may be used.

You may lose marks if you do not show your working or if you do not use appropriate units.

At the end of the examination, fasten all your work securely together.

The number of marks is given in brackets [ ] at the end of each question or part question.

This document consists of **16** printed pages.

**Section A**

Answer **all** the questions in this section. Answer in the spaces provided.

**1** A car of mass 800 kg is travelling at a speed of 25 m/s along a straight, horizontal road.

**(a)** State how *velocity* differs from *speed*.

.....  
.....[1]

**(b)** The driver presses the accelerator and the speed of the car starts to increase from 25 m/s. The car accelerates at 1.5 m/s<sup>2</sup>.

**(i)** Calculate the resultant force acting on the car as it accelerates.

force = .....[2]

**(ii)** Explain why the forward force acting on the car due to the engine is greater than the value in **(b)(i)**.

.....  
.....  
.....  
.....[2]

**(iii)** Determine the speed of the car 4.0 s after it starts to accelerate.

speed = .....[2]

2 Fig. 2.1 shows a bed that folds away against a wall during the day.

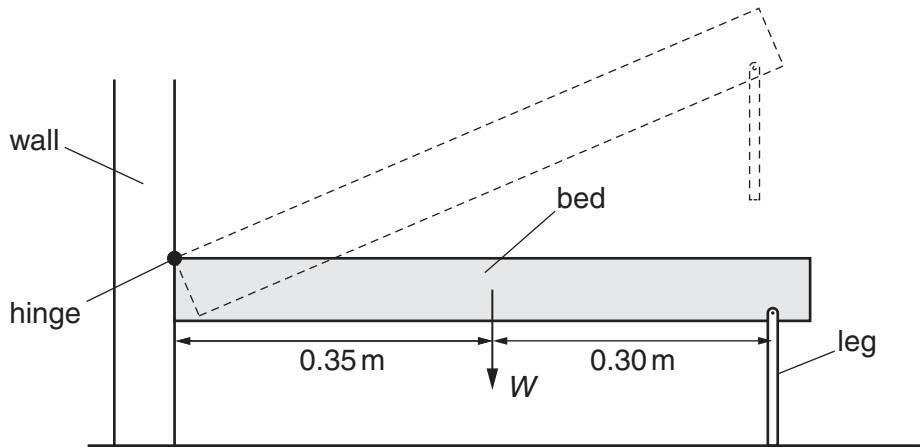

**Fig. 2.1** (not to scale)

When it is horizontal, the bed is supported on one side by a hinge and on the other side by two legs. The weight  $W$  of the bed acts through its centre of mass, which is at a horizontal distance of 0.35 m from the hinge.

(a) The mass of the bed is 26 kg. The gravitational field strength  $g$  is 10 N/kg.

Calculate the weight  $W$  of the bed.

$W = \dots\dots\dots$  [1]

(b) (i) State the principle of moments.

.....  
 .....  
 .....  
 ..... [2]

(ii) Determine the size of the total upward force exerted on the bed by the two legs when the bed is horizontal.

total force =  $\dots\dots\dots$  [3]

3 A large power station burns oil to heat water in a boiler.

(a) State the name of the form of energy stored in the oil before it is burnt.

.....[1]

(b) (i) State and explain whether oil is a renewable or a non-renewable energy source.

.....  
.....  
.....[1]

(ii) Describe one environmental issue caused by burning oil to generate electricity in a power station.

.....  
.....[1]

(c) (i) State what is meant by *efficiency*.

.....  
.....[1]

(ii) The efficiency of the power station is 0.38 (38%). Its electrical power output is  $1.9 \times 10^9$  W.

Calculate

1. the input power to the power station,

input power = .....[2]

2. the energy wasted in 2.0 hours.

energy wasted = .....[2]

- 4 A lamp is positioned at the bottom of a small pool of water. The critical angle for light passing from water into air is  $49^\circ$ .

(a) Explain what is meant by the term *critical angle*.

.....

.....

.....

.....[2]

(b) The lamp sends light towards the surface of the pool.

Fig. 4.1 shows three rays of light that are at  $30^\circ$ ,  $60^\circ$  and  $90^\circ$  to the horizontal.

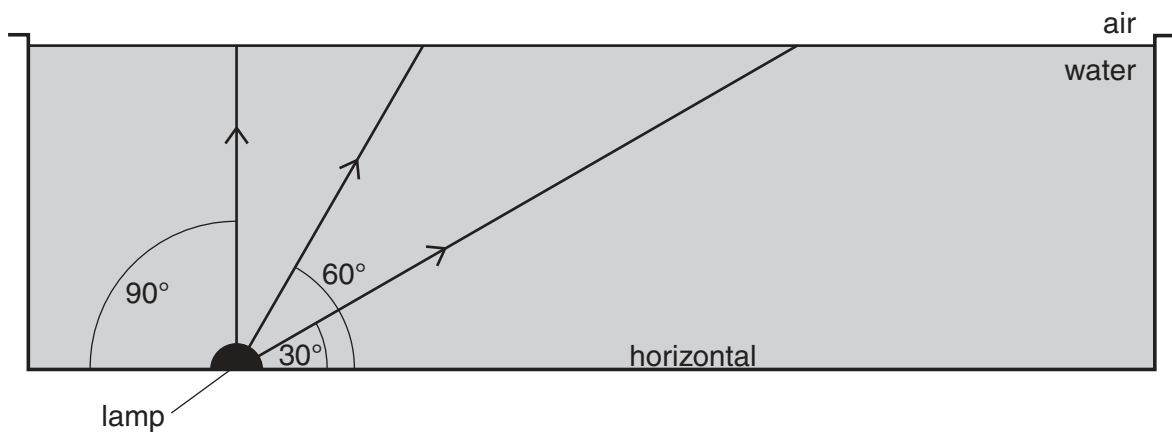

**Fig. 4.1**

On Fig. 4.1, draw the path taken by each of the three rays after they strike the surface of the water. [3]

- 5 Fig. 5.1 shows a loudspeaker inside a glass bell-jar that contains air.

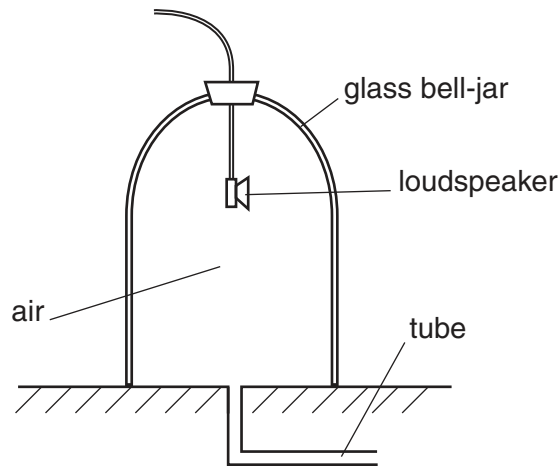

**Fig. 5.1**

The loudspeaker produces a sound of frequency 2200 Hz.

- (a) State what is meant by the *frequency* of a sound.

.....  
 .....  
 ..... [1]

- (b) (i) The speed of sound in air is 330 m/s.

Calculate the wavelength of the sound in the air.

wavelength = ..... [2]

- (ii) The sound passes from the air into the glass.

State what happens to

1. the frequency of the sound,

.....

2. the speed of the sound.

.....

[1]

(c) (i) Describe

1. how sound is produced by the loudspeaker,

.....  
.....  
.....[1]

2. how sound is transmitted through the air.

.....  
.....  
.....[2]

(ii) A pump is connected to the tube at the bottom of the glass bell-jar. The pump is switched on and it removes the air from the glass bell-jar.

Explain why the volume of the sound heard outside the glass bell-jar decreases.

.....  
.....  
.....[1]

- 6 Two flexible iron strips, WX and YZ, are placed close to each other inside a solenoid (long coil). The end W of WX and the end Z of YZ are held firmly in position.

Fig. 6.1 shows that the solenoid is connected to a d.c. power supply and a switch.

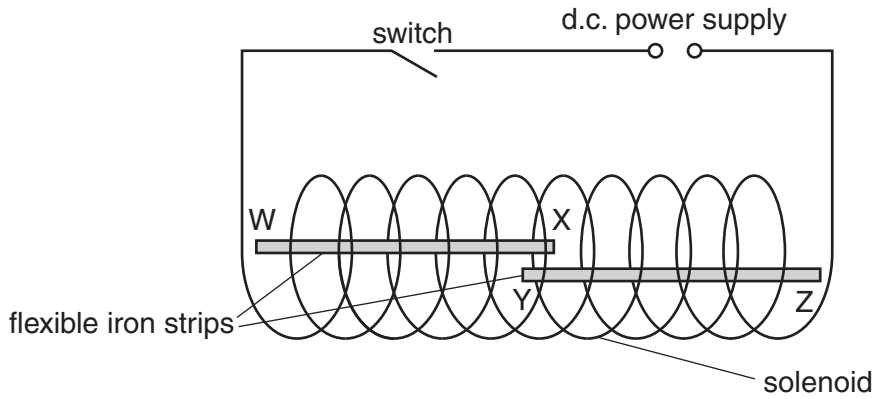

**Fig. 6.1**

The switch is closed and there is an electric current in the solenoid.

End W of flexible iron strip WX becomes a magnetic S-pole.

- (a) (i) State the type of magnetic pole produced at X, Y and Z.

1. X .....-pole
2. Y .....-pole
3. Z .....-pole

[2]

- (ii) State and explain what happens to X and Y because the flexible iron strips are magnetised.

.....  
 .....[1]

- (b) A relay operates a switch in one circuit using the current in a different circuit.

State one example of a relay used in this way and explain why a relay is used.

.....  
 .....  
 .....  
 .....  
 .....[2]



7 The a.c. mains electricity system in a house consists of three wires: the live, the neutral and the earth.

(a) (i) State the purpose of the live wire.

.....  
.....[1]

(ii) Explain why the neutral wire is needed.

.....  
.....[1]

(b) Each circuit in the house includes a fuse for protection.

(i) An electrical appliance is switched on and the current in the fuse becomes greater than the rating of the fuse.

State and explain what happens.

.....  
.....  
.....[2]

(ii) State and explain in which of the three wires the fuse is located.

.....  
.....  
.....  
.....[2]

## Section B

Answer **two** questions from this section. Answer in the spaces provided.

- 8 Sodium-24 and sodium-23 are two of the isotopes of sodium. Sodium-24 is a radioactive isotope that emits beta-particles and gamma-rays as it decays.

(a) The nuclide notation for the isotope sodium-24 is  ${}_{11}^{24}\text{Na}$ .

- (i) Describe the composition and structure of a neutral atom of sodium-24.

.....  
 .....  
 .....  
 .....  
 .....[3]

- (ii) State how the composition of a nucleus of sodium-24 differs from the composition of a nucleus of sodium-23.

.....  
 .....[1]

- (b) A nucleus of sodium-24 decays. It emits a beta-particle and produces a nucleus of an isotope of magnesium (Mg).

- (i) State the name of the particle that is identical to a beta-particle.

.....[1]

- (ii) Complete the nuclide equation for the emission of a beta-particle ( $\beta$ ) by sodium-24.

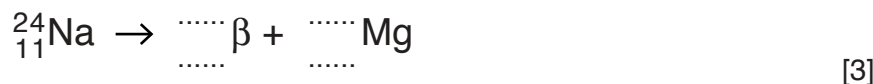

- (c) When it decays, sodium-24 also emits gamma-rays.

State what gamma-rays are.

.....  
 .....  
 .....[2]

- (d) Fig. 8.1 shows a beam of beta-particles and a beam of gamma-rays entering the electric field between two oppositely charged plates.

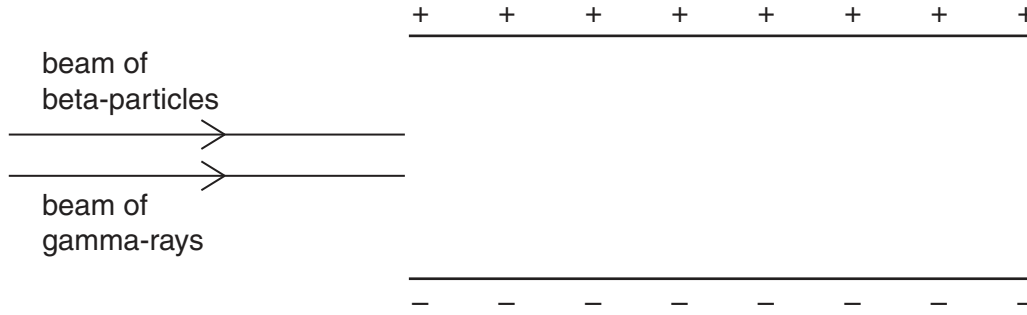

Fig. 8.1 (not to scale)

- (i) On Fig. 8.1, draw the path of the beta-particles in the electric field between the charged plates. [1]
- (ii) On Fig. 8.1, draw the path of the gamma-rays in the electric field between the charged plates. [1]
- (iii) Explain why the path taken by the beta-particles differs from that taken by the gamma-rays.

.....  
 .....  
 .....[1]

- (e) Sodium-24 is sometimes used in diagnosing medical conditions. The half-life of sodium-24 is 15 hours.

Explain one reason why a half-life of 15 hours makes the isotope suitable for use in the human body.

.....  
 .....  
 .....  
 .....[2]



- (ii) The e.m.f. of the power supply and the e.m.f. of the battery act against each other in opposite directions in the circuit.

The e.m.f. of the battery is 3.7V.

- 1. Calculate the resultant e.m.f. in the circuit.

resultant e.m.f. = .....[1]

- 2. Calculate the current in the circuit.

current = .....[2]

- 3. The current in the circuit remains constant as the battery is charged.

Calculate the charge that passes through the resistor in 1.5 hours.

charge = .....[3]

- (c) A battery charger has a plastic casing and double insulation. The battery charger is not earthed.

Explain why it is not necessary for the battery charger to be earthed.

.....  
.....  
.....  
.....[2]

10 A particular type of cooking oil is a liquid at room temperature.

(a) At room temperature, air is easily compressed but the oil cannot be compressed.

Explain, in terms of molecules,

(i) why the density of the oil is much greater than that of a gas,

.....  
 .....  
 .....[1]

(ii) why the oil cannot be compressed.

.....  
 .....  
 .....[1]

(b) Some of the oil is poured into a metal pan. The oil in the pan has a mass of 680g.

(i) The density of the oil is  $0.85 \text{ g/cm}^3$ .

Calculate the volume of oil in the pan.

volume = .....[2]

(ii) The pan is placed on an electric hotplate, as shown in Fig. 10.1.

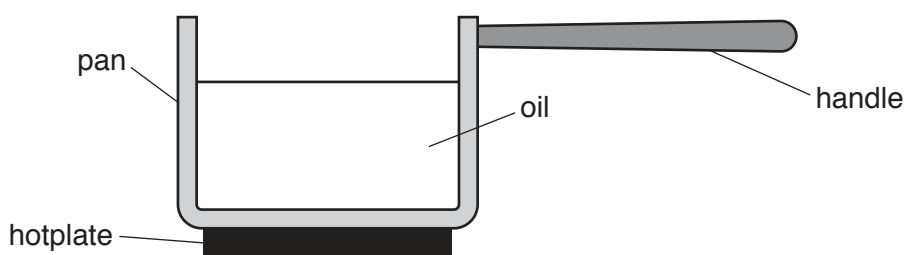

Fig. 10.1

1. Explain, in terms of molecules or free electrons, how thermal energy is conducted through the metal base of the pan.

.....  
.....  
.....  
.....  
.....  
.....  
.....[3]

2. Explain how thermal energy spreads to all the oil in the pan.

.....  
.....  
.....  
.....  
.....  
.....  
.....[3]

3. Suggest and explain a suitable material for the handle of the pan.

.....  
.....  
.....[1]

**Please turn over for part (c).**

(c) The specific heat capacity of the oil is  $2.0\text{ J}/(\text{g } ^\circ\text{C})$ . The oil is heated from  $20^\circ\text{C}$  to its boiling point of  $260^\circ\text{C}$ .

(i) State what is meant by *boiling point*.

.....  
.....[1]

(ii) Calculate the thermal energy needed to heat the 680 g of oil to its boiling point.

thermal energy = .....[2]

(iii) Suggest one reason why the energy output from the hotplate, when heating the oil, is larger than the value calculated in (c)(ii).

.....  
.....  
.....[1]

---

Permission to reproduce items where third-party owned material protected by copyright is included has been sought and cleared where possible. Every reasonable effort has been made by the publisher (UCLES) to trace copyright holders, but if any items requiring clearance have unwittingly been included, the publisher will be pleased to make amends at the earliest possible opportunity.

To avoid the issue of disclosure of answer-related information to candidates, all copyright acknowledgements are reproduced online in the Cambridge International Examinations Copyright Acknowledgements Booklet. This is produced for each series of examinations and is freely available to download at [www.cie.org.uk](http://www.cie.org.uk) after the live examination series.

Cambridge International Examinations is part of the Cambridge Assessment Group. Cambridge Assessment is the brand name of University of Cambridge Local Examinations Syndicate (UCLES), which is itself a department of the University of Cambridge.